

# OPERATING INSTRUCTIONS

## TYPE 1308-A

# AUDIO OSCILLATOR and POWER AMPLIFIER

Form 1308-0100-B

May, 1966

ID-1051

Copyright 1963 by General Radio Company  
West Concord, Massachusetts, USA

GENERAL RADIO COMPANY  
WEST CONCORD, MASSACHUSETTS, USA

## TABLE OF CONTENTS

	Page
Section 1. INTRODUCTION . . . . .	1
1.1 Purpose. . . . .	1
1.2 Description . . . . .	1
Section 2. INSTALLATION . . . . .	2
2.1 Connection to Power Supply . . . . .	2
2.2 Mounting . . . . .	2
2.3 Ventilation. . . . .	3
2.4 Grounding . . . . .	3
2.5 Output Connections . . . . .	3
Section 3. OPERATING PROCEDURE. . . . .	4
3.1 Turning on the Instrument . . . . .	4
3.2 Setting the Controls. . . . .	4
3.3 Operation of the Overload Circuitry . . . . .	4
3.4 Operation With DC Applied to the Output. . . . .	4
3.5 Operation as an Amplifier, With an External Signal Source. . . . .	5
Section 4. PRINCIPALS OF OPERATION. . . . .	5
4.1 General. . . . .	5
4.2 Oscillator . . . . .	5
4.3 Amplifier Section . . . . .	6
4.4 Output Transformer . . . . .	7
4.5 Metering Circuits . . . . .	7
4.6 Overload Circuit. . . . .	7
4.7 Power Supplies . . . . .	7
Section 5. SERVICE AND MAINTENANCE . . . . .	8
5.1 Warranty . . . . .	8
5.2 Service. . . . .	8
5.3 Minimum Performance Limits . . . . .	9
5.4 Routine Maintenance . . . . .	9
5.5 Removal From the Case . . . . .	9
5.6 Internal Adjustments . . . . .	9
5.7 Trouble Analysis . . . . .	9
5.8 Reapplying Power After Servicing . . . . .	10

## SPECIFICATIONS

### FREQUENCY

**Range:** 20 to 20,000 c/s in 3 decade ranges. **Accuracy:**  $\pm 3\%$ .

**Stability:** Approx 0.1% from no load to full load; short-term, approx 0.03%; warm-up drift at full load, 100 c/s, 1.5%; 1 kc/s and 10 kc/s, 0.03%.

### OUTPUT

**Power:** 200 VA, 50 c/s to 1 kc/s; see curves.

**Load Power Factor:** (At full ratings) any for continuous operation to 30°C ambient or intermittent operation to 50°C ambient. 0.7 to 1.0 for continuous operation to 50°C ambient.

**Overload Protector:** Electronic overload circuit trips at about  $1\frac{1}{2}$  full-scale current (manual reset); thermal protection on transistor heat sink (automatic reset).

**Voltage:** 0 to 400 V, rms, in 5 ranges of 0 to 4, 12.5, 40, 125, and 400 V. Regulation (see curves) less than 20%, no load to full load, 20 c/s to 1 kc/s (bandwidth greater than 10 kc/s provides essentially instantaneous regulation).<sup>1</sup>

**Output Voltmeter:** 0 to 5, 15, 50, 150, 500 V, full scale.

**Current:** 0 to 5 A, rms, in 6 ranges of 0 to 0.016, 0.05, 0.16, 0.5, 1.6, and 5 A. Ammeter output monitor, 0 to 0.05, 0.16, 0.5, 1.6, and 5 A full scale.

**Optimum Load Impedances:** 0.8, 2.5, 8, 80, 800  $\Omega$ . Operates satisfactorily with higher impedance or nonlinear loads. Output transformer passes dc equal to rated ac. Amplifier output imped-

ance is approximately 0.3, 0.3, 1.6, 19, and 220 ohms, respectively, below 1 kc/s.

**Harmonic Distortion:** 1%, 100 c/s to 10 kc/s (with linear loads at rated output, see curves); 2%, 50 c/s to 100 c/s, with linear loads. With non-linear loads additional distortion in the load voltage is caused by the voltage drop in the amplifier output impedance. **Hum:** 50 dB or more below max output.

### AMPLIFIER

**Sensitivity:** About 2 V for full output. **Input Impedance:** 10 k $\Omega$ .

### GENERAL

**Power Required:** 105 to 125 or 210 to 250 V, 50 to 60 c/s, 70 to 500 W depending on load. For 50-cycle supply, maximum output must be reduced slightly.

**Accessories Supplied:** TYPE CAP-22 Power Cord, spare fuses.

### MECHANICAL DATA Rack-Bench Cabinet

Model	Width		Height		Depth		Net Wt		Ship Wt	
	in	mm	in	mm	in	mm	lb	kg	lb	kg
Bench	19	485	7	180	16 $\frac{1}{4}$	414	91	42	145	67
Rack	19	485	7	180	15*	385	91	42	145	67

\* Behind panel.

See also *General Radio Experimenter*, January 1964.

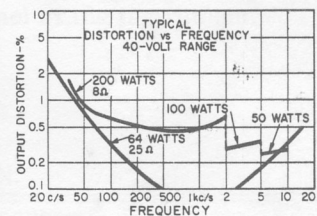
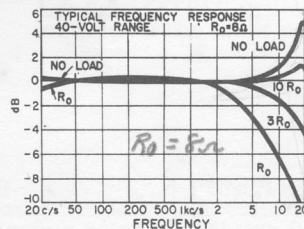
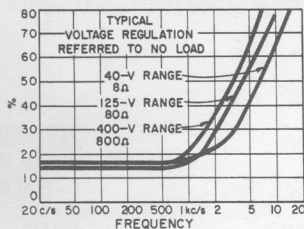
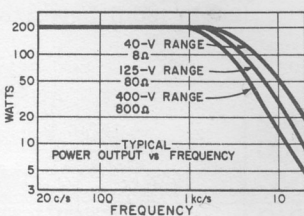





*Figure 1-1. Type 1308-A Audio Oscillator and Power Amplifier.*



## SECTION I

## INTRODUCTION

## WARNING

*This instrument is capable of delivering lethal energy. All loads and connections should be well insulated to avoid accidental contact. Always turn the OUTPUT to zero before disconnecting the load or changing the range.*

## 1.1 PURPOSE.

The Type 1308-A Audio Oscillator and Power Amplifier (Figure 1-1) is an ac power source whose frequency can be varied over the entire audio range. Because its output circuit will pass direct current, it is an excellent source of power for the testing of devices over a wide range of supply frequencies. It provides a low-distortion signal to nonlinear loads, such as capacitor-input rectifier systems. Its high output power makes it useful for driving shake tables and other vibration equipment. It can also be used to isolate sensitive equipment from power line transients.

The instrument has many uses as a general-purpose, audio-frequency, power amplifier, operating from an external input signal.

## 1.2 DESCRIPTION.

**1.2.1 GENERAL.** This instrument combines a capacitor-tuned Wien-Bridge oscillator, a low-distortion power amplifier, and a tapped output transformer.

Solid-state circuitry is used throughout. The power amplifier can be easily disconnected from the oscillator, for use with an external signal source. Output voltage and current meters are provided, and the output is monitored by an overload circuit that turns off the output when safe limits are exceeded.

**1.2.2 CONTROLS.** The following table lists the controls located on the front panel of the instrument:

NAME	SCHEMATIC DIAGRAM REFERENCE, FIGURE 5-3	TYPE	FUNCTION
FREQUENCY	C102, C103	Continuous rotary control with dial	Adjusts frequency.
FREQUENCY RANGE	S101	3-position rotary switch	Selects frequency range.
VOLTS	S301	5-position rotary switch	Selects maximum output voltage and full-scale reading of voltmeter.
AMPS	S401	6-position rotary switch	Selects full-scale reading of ammeter and overload-circuit trip point.
OUTPUT	R201	Continuous rotary control	Adjusts gain of amplifier.
OVERLOAD-RESET	S402	Spring-return toggle switch	Resets overload circuit.
POWER-OFF	S501	Toggle switch	Connects and disconnects line input power.



**1.2.3 CONNECTORS.** The following table lists the connectors located on the rear panel of the Type 1308-A Audio Oscillator and Power Amplifier:

NAME	SCHEMATIC DIAGRAM REFERENCE, FIGURE 5-3	TYPE	FUNCTION
None	PL501	Three-terminal male connector	Connection for power line.
OSC OUTPUT	J201	Binding post	Output connection from oscillator.
AMP INPUT	J202	Binding post	Input connection to amplifier.
OUTPUT	J301, J302	Binding posts, pair	Output connection from amplifier.
None	SO301	Multipoint connector	Output connection from amplifier.

**SECTION 2**

**INSTALLATION**

**2.1 CONNECTION TO POWER SUPPLY.**

Connect the Type 1308-A to a source of power as indicated by the legend at the input socket on the rear panel of the instrument; use the power cord provided. Instruments are normally supplied for 115-volt operation, but the power transformer can be reconnected for 230-volt service (see schematic diagram, Figure 5-3). When changing connections, be sure to replace line fuses with those of the current rating for the new input voltage (refer to Parts List). Appropriate measures should be taken so that the legend indicates the new input voltage. On instrument changed from 230 to 115 volts, this simply means removal of the 230-volt nameplate; a 115-v legend is marked beneath. For instruments changed to 230 volts, a nameplate (Type 5590-1664) may be ordered from General Radio.

Operation at 50 cps differs only in slower running of the cooling fan. This may cause the thermal breaker to trip at an output of less than 200 volt-amperes, with reactive loads.

**2.2 MOUNTING.**

The instrument is available equipped for either bench or relay-rack mounting. For bench mounting (Type 1308-AM) aluminum end frames are supplied to fit the ends of the cabinet. Each end frame is attached to the instrument with two panel screws and four No. 10-32 round-head screws with notched washers.

For rack mounting (Type 1308-AR), special rack-mounting brackets are supplied to attach the cabinet and instrument to the relay rack (see Figure 2-1). These brackets permit either the cabinet or the instrument to be withdrawn independently of the other.

To install the instrument in a relay rack:

- a. Attach each mounting bracket (A) to the rack with two No. 12-24 round-head screws (B). Use the inside holes on the brackets.
- b. Slide the instrument onto the brackets as far as it will go.
- c. Insert the four panel screws (C) with attached washers through the panel and the bracket, and thread

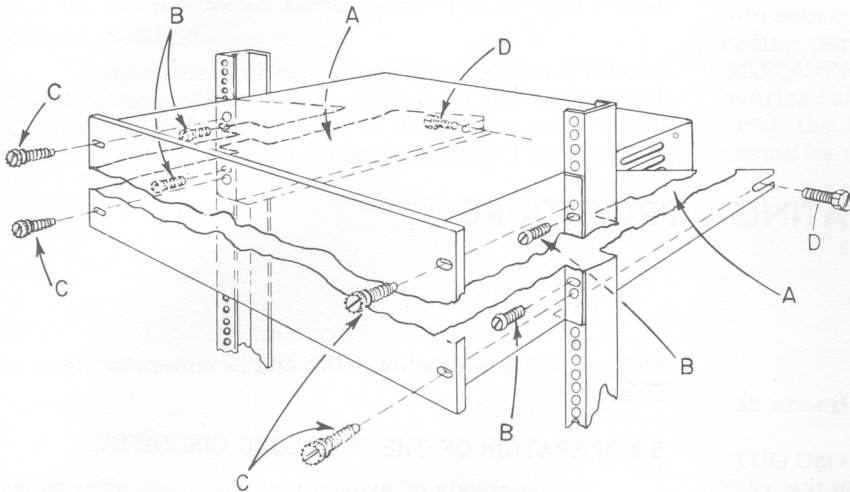

Figure 2-1. Installation of Type 1308-A in relay rack.

them into the rack. The washers are provided to protect the face of the instrument.

d. Toward the rear of each bracket, put a thumb-screw (D) through the slot in the bracket and into the hole in the side of the cabinet.

e. On the rear of the cabinet, remove the two round-head screws holding the cabinet to the instrument.

To remove the instrument from the rack, remove only the four panel screws (C) with washers and draw the instrument forward. To remove the cabinet and leave the instrument mounted in the rack, remove only the two thumbscrews (D) at the rear of the brackets and from the rear of the rack, pull the cabinet off of the instrument.

### 2.3 VENTILATION.

Forced air is used for normal cooling of this instrument, and any interruption of this air flow will cause overheating. Avoid mounting the instrument so that the flow of air is impeded; keep the air filter clean (refer to paragraph 5.4).

### 2.4 GROUNDING.

The instrument is normally operated with the chassis grounded through the three-wire power cord. If the cord is not used, make the ground connection, if one is required, at J303 on the rear panel (Figure 5-3).

### 2.5 OUTPUT CONNECTIONS.

#### WARNING

*Always turn the OUTPUT control to zero (fully CCW) before connecting or disconnecting the load.*

Connect the load either to the pair of OUTPUT binding posts or to the multipoint connector on the rear panel. Figure 2-2 shows the output connections. The OUTPUT terminals are not connected to ground; either may be used above ground. However, the gray terminal should be nearer ground potential if there is a choice, to give rated frequency response. The connecting link attached to the metal post can be used to ground the gray terminal.

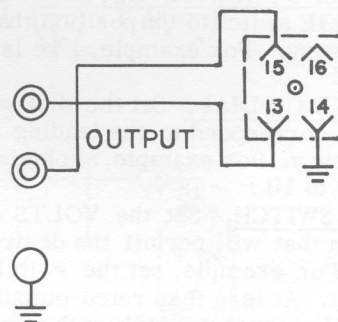

Figure 2-2. Output connections.





SECTION 3

OPERATING PROCEDURE

3.1 TURNING ON THE INSTRUMENT.

Install the load and connect the power line as described in the previous section.

Be sure the metal link connects the OSC OUTPUT terminal to the AMP INPUT terminal, on the rear panel of the instrument. Turn the OUTPUT control counterclockwise until the switch on the control is actuated. This switch shorts the output and prevents turn-on transients from affecting the load circuitry. It also prevents any direct current in the output circuit from passing through the transformer.

Turn on the power by setting the POWER switch (Figure 1-1) in the "up" position. The lamp above the switch should light. No appreciable warm-up time is required.

Reset the overload circuitry, if necessary, by pushing the OVERLOAD switch to the RESET position (down). With some load impedances, it may be necessary to advance the AMPS switch clockwise, to a higher current range, before the overload circuitry can be reset.

3.2 SETTING THE CONTROLS.

**3.2.1 FREQUENCY RANGE SWITCH.** Set the FREQUENCY RANGE switch to the position that includes the desired frequency. For example, 1 kc is between 200 cps and 2 kc.

**3.2.2 FREQUENCY DIAL.** Set the dial so that the indicated digits correspond to the leading digits of the desired frequency. For example, to obtain 1 kc, set the frequency dial to 10.

**3.2.3 VOLTS SWITCH.** Set the VOLTS switch to the lowest position that will permit the desired voltage to be obtained. For example, set the switch to 125 for a 115-volt output. At less than rated output current, the instrument will operate properly with output voltages in excess of those shown on the switch. For this reason the scales of the voltmeter extend somewhat beyond the nominal limit of the ranges indicated on the VOLTS switch. The accuracy of the voltmeter is approximately  $\pm 3\%$  of full scale.

**3.2.4 AMPS SWITCH.** Set the AMPS switch to the lowest position that will provide the desired output current. This switch setting also determines the ammeter range and sets the overload circuit to trip at about 1 1/2 times full scale on the ammeter, to protect loads from the inadvertent application of high power.

**3.2.5 OUTPUT CONTROL.** Advance the OUTPUT control clockwise until the desired voltage is indicated by the voltmeter, with the range determined by the VOLTS switch. The accuracy of the ammeter is approximately

$\pm 3\%$  of full scale below 10kc and is somewhat less at 20kc.

3.3 OPERATION OF THE OVERLOAD CIRCUITRY.

Two methods of preventing overloads are used in the Type 1308-A. The electronic current-overload circuit breaker is actuated by the current meter and the drive voltage, as described in paragraph 3.2.4. It can be reset at any time by momentarily holding the OVERLOAD switch in the RESET position. A thermal circuit breaker is also included to shut off the main power supply whenever the internal temperature of the transistor heat-sinks becomes excessive. In this condition, the instrument will not function; even with the POWER switch on, all power is removed. Allow the instrument to cool before further operation is attempted.

3.4 OPERATION WITH DC APPLIED TO THE OUTPUT.

For some applications, particularly the testing of iron-core devices, a composite signal, containing both ac and dc, is required.<sup>1</sup> The low dc impedance of the output transformer winding permits the passage of a large direct current, whose value depends upon the settings of the VOLTS and AMPS switches, as given in Table 1. The allowable dc current is always as great as the settings of the AMPS switch and can be much greater in some cases. The limitations listed are for continuous duty and are determined by the temperature rise in the output transformer.

TABLE 1

The direct current that can be passed through the output circuit depends on the settings of both the AMPS and VOLTS switches, as shown below.

Volts Switch Setting	Amps Switch Setting					
	5.0	1.6	0.5	0.16	.05	.016
400			0.5	0.5	.16	.16
125		1.6	1.6	1.6	.16	.16
40	5.0	1.6	1.6	1.6	.16	.16
12.5	5.0	1.6	1.6	1.6	.16	.16
4.0	5.0	1.6	1.6	1.6	.16	.16

1. R.G.Fulks and H.P.Hall, "A New System For Measuring the Inductance of Iron-Core Coils," General Radio Experimenter, Vol. 36, No. 5, May, 1962.

### 3.5 OPERATION AS AN AMPLIFIER, WITH AN EXTERNAL SIGNAL SOURCE.

Remove the link connecting the OSC OUTPUT terminal to the AMP INPUT terminal, on the rear panel. Connect the external signal source to the AMP INPUT terminal and the metal ground terminal. The operating

procedure is then the same as that described in the preceding paragraphs, but the FREQUENCY dial and the FREQUENCY RANGE switch are not used. Since the overload circuit is triggered by signal levels that overdrive the amplifier, noise or other transient signals should be amplitude limited.

## SECTION 4

# PRINCIPLES OF OPERATION

### 4.1 GENERAL.

The Type 1308-A Audio Oscillator and Power Amplifier combines an oscillator, a low-distortion power amplifier, and a tapped output transformer, to provide a versatile signal source which finds many uses. These sections are connected together in cascade, as shown in the elementary circuit diagram, Figure 4-1.

### 4.2 OSCILLATOR.

4.2.1 The oscillator section includes a variable-capacitor-tuned, Wien-Bridge network and a transistor feed-

back amplifier, to form a low-distortion signal source. Figure 4-2 is a simplified schematic diagram of the oscillator.

4.2.2 FREQUENCY-DETERMINING NETWORK. The Wien Bridge can be thought of as consisting of two parts: a frequency-determining network (capacitors  $C_a$  and  $C_b$  and resistors  $R_a$  and  $R_b$ ) which provides positive feedback to sustain oscillation; and a resistive divider (resistors  $R_{121}$  and  $R_{115}$ ) which provides negative feedback to stabilize the amplitude. The frequency-determining network has the following transfer function:

$$\frac{e_{out}}{e_{in}} = \frac{j \frac{f}{f_o}}{1 - \left(\frac{f}{f_o}\right)^2 + 3j\left(\frac{f}{f_o}\right)}$$

where  $f$  = frequency

$$f_o = \frac{1}{2\pi RC}$$

$$R = R_a = R_b$$

$$C = C_a = C_b$$

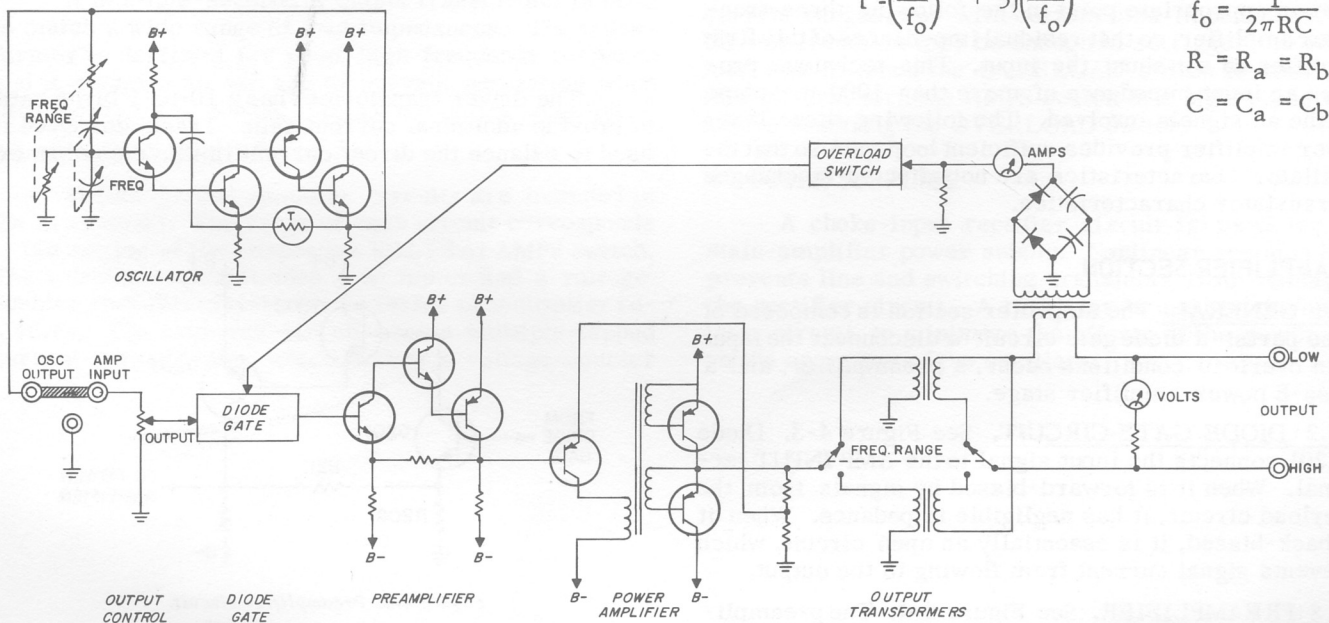

Figure 4-1. Elementary circuit diagram for Type 1308-A Audio Oscillator and Power Amplifier.

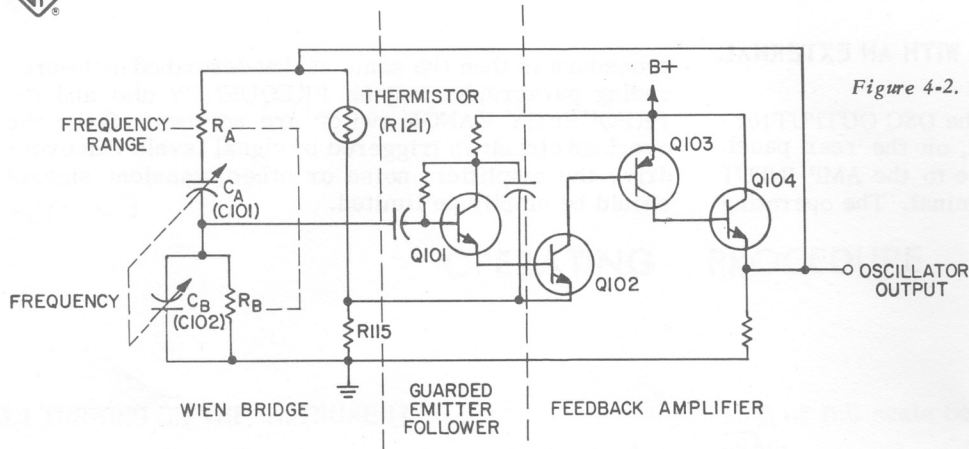

Figure 4-2. Simplified schematic diagram of the oscillator.

At some frequency,  $f_0$ , this function equals  $+\frac{1}{3}$ . This frequency is determined by the variable capacitor  $C_a$  and  $C_b$ , and one of three pairs of precision metal-film resistors,  $R_a$  and  $R_b$ , selected by the FREQUENCY RANGE switch.

The resistive divider is used to set the gain of the associated amplifier chain to +3. The net gain of the loop is then +1, and the circuit oscillates at the frequency  $f_0$ . The resistance of a small bead thermistor, R121, automatically adjusts to the value needed to maintain oscillation. The time constant of the thermistor is short enough to provide a rapid correction for amplitude variations, but long enough to cause little distortion at the lower frequencies. The thermistor operates at a high temperature, in an evacuated bulb, to minimize the effects of ambient temperature.

**4.2.3 OSCILLATOR AMPLIFIER.** The amplifier uses four transistors in a novel feedback circuit to obtain the extremely high input impedance required to avoid loading the frequency-determining network. Transistor Q101 is an emitter-follower circuit in which the transistor and its biasing network are guarded by a potential from an appropriate point in the following three-transistor amplifier, so that residual impedances of this first amplifier do not shunt the input. This technique provides an input impedance of more than 1000 megohms for the ac signals involved. The following three-transistor amplifier provides sufficient loop gain so that the oscillator characteristics are not affected by changes in transistor characteristics.

**4.3 AMPLIFIER SECTION.**

**4.3.1 GENERAL.** The amplifier section is composed of three parts: a diode gate circuit to disconnect the input when overload conditions occur, a preamplifier, and a Class-B power-amplifier stage.

**4.3.2 DIODE GATE CIRCUIT.** See Figure 4-3. Diode CR201 connects the input signal to the AMP INPUT terminal. When it is forward-biased by signals from the overload circuit, it has negligible impedance. When it is back-biased, it is essentially an open circuit, which prevents signal current from flowing to the output.

**4.3.3 PREAMPLIFIER.** See Figure 4-4. The preamplifier consists of three transistors in a feedback circuit and provides a relatively high input impedance, with sufficient power to drive the output stage.

**4.3.4 POWER-AMPLIFIER STAGE.** See Figure 4-5. A two-transistor, Class-A, driver stage is transformer coupled to the output stage. The high collector impedance of the driver, Q205, provides a high impedance to drive the Class-B output stage, thus utilizing the relatively linear current-to-current transfer ratio of the output transistors. This produces a minimum of crossover distortion without the use of temperature-sensitive biasing networks.<sup>1</sup>

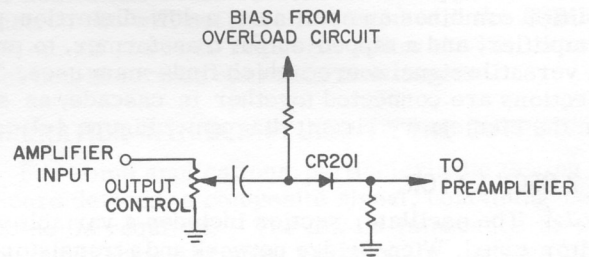

Figure 4-3. Diode gate circuit.

The driver transformer has a 10-to-1 turns ratio to provide additional current gain. Transistor Q204 is used to balance the direct current in this transformer.

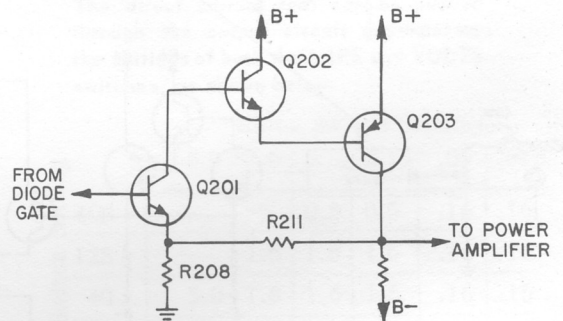

Figure 4-4. Preamplifier circuit.

1. J.J.Faran and R.G.Fulks, "High Impedance Driver For the Elimination of Crossover Distortion," I.R.E. Transactions, Vol. AU10, July-Aug. 1962, No. 4, pp 99-105.



Each side of the Class-B output circuit uses eight transistors, with .07- or .08-ohm resistors to split the current equally. The drive current for the output is limited by the Class-A driver. Without this, a short circuit in the output could cause the output stage to draw very heavy current, probably with disastrous results. The over-all feedback is returned to the emitter of transistor Q205, to reduce distortion and to provide a low dynamic output impedance. The ten output transistors are mounted on a large forced-air-cooled aluminum heat sink. The efficient removal of heat is essential in this instrument because the amplifier efficiency can be near zero when it is driving a reactive load. Therefore all the input power must be dissipated in the output transistor.

circuit and the ammeter. The meter current also passes through the overload circuit. The meter deflection is proportional to the average value of the rectified ac signal.

**4.6 OVERLOAD CIRCUIT.**

An overload circuit is included to avoid excessive output current. This transistor circuit trips when the ammeter current reaches approximately 1 1/2 times full scale, or when the drive voltage causes saturation of the output stage. Tripping of the overload circuit causes the OVERLOAD lamp to light and removes the forward bias from the input diode gate, which in turn disconnects the input to the amplifier. The RESET switch restores

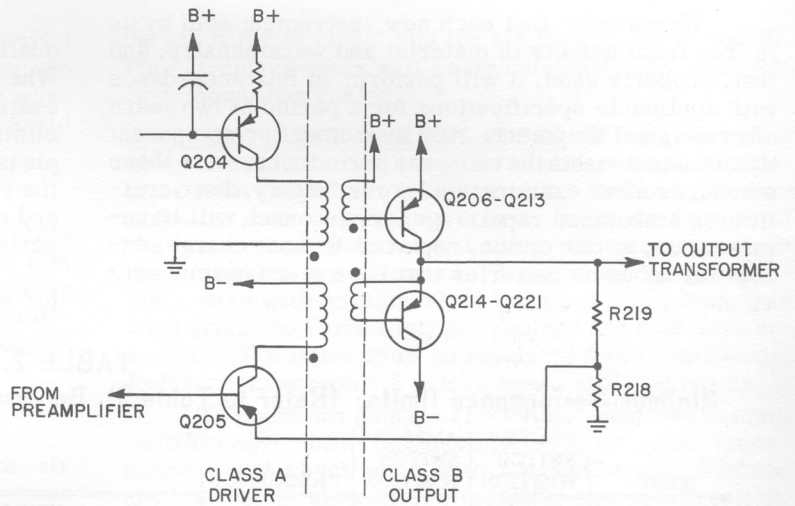

Figure 4-5. Power-amplifier circuit.

**4.4 OUTPUT TRANSFORMER.**

A multiple-secondary output transformer is used to match a wide range of load impedances. The transformer is designed for good high-frequency response and it contains an air gap to prevent saturation when direct current is passed through the output windings.

**4.5 METERING CIRCUITS.**

Voltmeter and ammeter circuits are included in the instrument. The range of each circuit corresponds to the setting of the respective VOLTS or AMPS switch. The voltmeter circuit uses a dc meter and a voltage-doubler rectifier circuit, with a series of multiplier resistors. The ammeter circuit uses a multiple-tapped current transformer, which drives a voltage-doubler

the circuit, which is triggered again if the cause of the excessive current has not been removed. On the lower current ranges, and with certain load impedances, the turn-on transient may be enough to retrigger the overload circuit when the OVERLOAD switch is reset. If this occurs, turn the AMPS switch to a higher position before resetting the OVERLOAD switch.

**4.7 POWER SUPPLIES.**

A choke-input rectifier circuit is used for the main-amplifier power supply. Nonlinear resistor R501 prevents line and switching transients from damaging the rectifier circuit. A regulator is used in the oscillator circuit, to minimize the effects of the power line on the operation of the oscillator.



## SECTION 5

## SERVICE AND MAINTENANCE

## 5.1 WARRANTY.

We warrant that each new instrument sold by us is free from defects in material and workmanship, and that, properly used, it will perform in full accordance with applicable specifications for a period of two years after original shipment. Any instrument or component that is found within the two-year period not to meet these standards after examination by our factory, district office, or authorized repair-agency personnel, will be repaired, or, at our option, replaced without charge, except for tubes or batteries that have given normal service.

## 5.2 SERVICE.

The two-year warranty stated above attests the quality of materials and workmanship in our products. When difficulties do occur, our service engineers will assist in any way possible. If the difficulty cannot be eliminated by use of the following service instructions, please write or phone our Service Department (refer to the rear cover), giving full information of the trouble and of steps taken to remedy it. Be sure to mention the serial and type numbers of the instrument.

Before returning an instrument to General Radio for service, please write to our Service Department or

TABLE 2.  
Minimum-performance limits. (Refer to Table 3). Be sure power line is 115 (or 230) volts, 60 cps.

TEST	VOLTS SWITCH POSITION	AMPS SWITCH POSITION	FREQUENCY		PARA-GRAPH REF.
1. Output Voltage	All Positions	5	1 kc	Attach an ac VTVM to the OUTPUT terminals. Adjust the OUTPUT control so that the voltmeter indicates the same as the setting of the VOLTS switch. The external voltmeter must indicate within $\pm 3\%$ of this value. Repeat for all settings of the VOLTS switch.	5.6
2. Frequency	12.5	5	20,100,200 cps 1kc, 2kc,10kc, 20kc	Attach a frequency counter or meter to the OUTPUT terminals. Adjust the output for 12.5 volts. Check that the output frequency corresponds to the setting of the frequency dial within $\pm 3\%$ .	5.7.3.1
3. Output Power	40	5	50 cps, 1kc	Attach an 8-ohm load resistor. Turn the OUTPUT control fully clockwise (or until clipping of the output waveform is observed on an oscilloscope). The voltmeter must indicate more than 40 volts.	5.7.3
4. Regulation	40	5	1kc	With no load, set the output for 40 volts. Attach an 8-ohm load. The voltmeter must indicate more than 32 volts.	5.7.3.4
5. Distortion	40	5	50 cps, 1kc	Connect a wave analyzer and an 8-ohm load to the OUTPUT terminals. Set the output to 40 volts. The harmonic distortion, as calculated from the following equation, must be less than 1% at 1 kc, 2% at 50 cps.  $\text{PERCENT DISTORTION} = \frac{1}{40} \sqrt{H_2^2 + H_3^2 + H_4^2 + H_5^2 + \dots + H_j^2}$ <p style="text-align: center;">where <math>H_2</math> is the rms value of the 2nd harmonic, <math>H_3</math> is the rms value of the 3rd harmonic, etc.</p>	5.7.5
6. Hum	40	5	1 kc	Connect a wave analyzer and an 8-ohm load to the OUTPUT terminals. Set the output to 40 volts. The rms hum, as calculated from the following equation, must be less than 0.32%.  $\text{PERCENT HUM} = \frac{1}{40} \sqrt{H_{60}^2 + H_{120}^2 + H_{180}^2 + \dots + H_j^2}$ <p style="text-align: center;">where <math>H_{60}</math> is the rms value of the 60-cycle component, <math>H_{120}</math> is the rms value of the 120-cycle component, etc.</p>	5.7.3
7. Overload Current	40	1.6	1 kc	Connect an 8-ohm load to the OUTPUT terminals. Advance the OUTPUT control slowly until the OVERLOAD lamp lights. At this point the voltmeter must indicate between 15 and 23 volts.	5.7.6

**TABLE 3.**  
Equipment required for minimum-performance tests listed in Table 2.

TEST NO. (TABLE 2)	INSTRUMENT	G R TYPE NUMBER OR EQUIVALENT
1	AC Vacuum-tube voltmeter	1800-A, 1803-A, 1806-A
2	Frequency counter or meter	1130-A, 1150-A, 1151-A; 1142-A
3,4,5, 6,7	Load resistor	8-ohm, 200-watt Resistor
3	Oscilloscope	Laboratory Type, 1 kc bandwidth, 10 v/cm sensitivity
5,6	Wave analyzer	736-A, 1900-A

nearest district office, requesting a Returned Material Tag. Use of this tag will ensure proper handling and identification. For instruments not covered by the warranty, a purchase order should be forwarded to avoid unnecessary delay.

### 5.3 MINIMUM PERFORMANCE LIMITS.

The Type 1308-A should perform within the limits described in Table 2 for normal operation. The test equipment required is listed in Table 3. If the instrument does not meet the minimum-performance specifications, refer to paragraph 5.7 for trouble-analysis procedures.

### 5.4 ROUTINE MAINTENANCE.

To maintain proper cooling efficiency, the air filter should be cleaned approximately every three months. Local air conditions should determine more precisely how often this is necessary. To clean the filter, release it from its holder, rap it gently to remove excess dirt, flush it from its dirty side with hot, soapy water, rinse it, and let it dry.

This cleaning of the air filter is the only routine maintenance required for the instrument.

### 5.5 REMOVAL FROM THE CASE.

To remove the outer case, loosen the two thumb-screws at the rear and slide the case back and off.

### 5.6 INTERNAL ADJUSTMENTS.

Normally, the factory-set adjustments described in Table 4 will not require any attention. They are given so that they may be readjusted on the few occasions when the user finds it necessary, such as after the replacement of a component.

### 5.7 TROUBLE ANALYSIS.

**5.7.1 INSTRUMENT INOPERATIVE.** (Pilot lamp does not light; fan does not operate.)

- Be sure the power line is properly connected.
- Replace the fuses if they have blown.
- If the instrument overheats, an internal thermal circuit breaker disconnects the input power. When this happens, check that the load circuits are not shorted,

the air filter is clean, and the air flow is not impeded. This circuit breaker will reset automatically when the instrument has cooled.

**5.7.2 INSTRUMENT BLOWS FUSES.** If the instrument blows fuses, the trouble may be in either the power supply or the output amplifier circuit. Remove the heat sinks by removing the six screws from the bottom of the instrument. Remove and check the transistors; replace any that are defective. Replace any fused resistance wire with an equivalent length of #26, manganin wire (refer to Parts List) and replace the heat-sink assembly. The latter must be insulated from the chassis. Refer to paragraph 5.8 before again applying power.

To check for damaged rectifiers, remove the main rectifier assemblies (mounted on top of the power transformer) and check each with an ohmmeter. Replace any that do not show a high resistance in one direction. The individual rectifiers are pressed into the aluminum block assembly. Refer to paragraph 5.8 before again applying power.

### 5.7.3 NO OUTPUT.

**5.7.3.1 Oscillator Not Working.** When the oscillator is working, a 1.2-volt (rms) signal will appear at the rear OSC OUTPUT jack. If the oscillator is not working:

- Be sure the dc voltage at A. T. #11 is approximately 15.0 volts. If it is not, the regulator circuit (Q501 and Q502) is at fault.
- Be sure the other dc voltages in the oscillator section are approximately as shown on the schematic diagram, Figure 5-3. If they are not, the trouble is in the amplifier section of the oscillator circuit.
- If the dc voltages are correct, the trouble is in the frequency-determining section of the oscillator. Determine which frequency ranges are inoperative, as a guide in locating the faulty components.

Connect an oscilloscope to the OSC OUTPUT jack and rotate the FREQUENCY dial. The presence of noise at the output indicates that dust or other foreign matter is shorting the capacitor plates.

**5.7.3.2 Overload Gate Not Working.** Turn the OUTPUT control fully clockwise with the OVERLOAD light turned off (reset if necessary). The dc voltage at the anode of CR 201 should be 3.0 volts. A higher value indicates that the overload circuit is not reset, that lamp P401 may be defective.





TABLE 4

Internal Adjustments. See Figures 5-1 and 5-2.

COMPONENT	FUNCTION	ADJUSTMENT PROCEDURE
C103, C104	Adjusts span of FREQUENCY dial	Set for accurate indication at high end of FREQUENCY dial and for minimum change in output level when FREQUENCY dial is turned rapidly.
R507	Sets output level of oscillator power-supply regulator	Adjust to give 15.0 volts dc between A.T. #11 and ground.
R403	Adjusts ammeter calibration	Set to give correct indication on ammeter, as measured on an external ammeter.
R301	Adjusts voltmeter calibration	Set to give correct indication on voltmeter, as measured on an external voltmeter.
R215	Balances direct current in amplifier driver transformer	Adjust for minimum distortion at 50 cps with full output voltage.

**5.7.3.3 Preamplifier Not Working.** With the overload gate working properly and the OUTPUT control turned fully clockwise, the oscillator signal should be present at the base of transistor Q202 and should be amplified by a factor of four as it appears at the base of transistor Q205. If it is not, remove Q205 and look for the signal at the collector of Q203. No signal at this point indicates that the trouble is in the preamplifier stage, Q201, Q202, or Q203.

**5.7.3.4 Power Amplifier Not Working.** With the preamplifier working properly, the signal at the amplifier output (the upper heat sink potential) should be approximately three times the signal at the base of Q205. If it is not, check transistors Q204 and Q205 and all wiring. Failure of an output transistor probably would not cause this trouble since, except for its power-handling capacity, the power amplifier will operate properly with any pair of the output transistors working.

**5.7.3.5 Output Circuit Not Working.** If the signal appears at the primary of the transformer, but not at the secondary, the transformer winding is open and must be replaced.

If the signal appears on the secondary taps of the output transformer, but not at the OUTPUT terminals, trace the signal through the various switches, as shown on the schematic diagram.

**5.7.4 NOISY OUTPUT.** A noisy or erratic output signal can be produced by a noisy transistor (Q101) or by foreign matter in the plates of capacitor C101/102 in the oscillator circuit. To confirm this, substitute an external oscillator for the internal oscillator, as described in paragraph 3.8, before replacing the transistor.

**5.7.5 DISTORTED OUTPUT.** Excessive distortion can be caused by improper operation of the diode gate, CR201 (refer to paragraph 5.7.3.2) or by improper balancing of the driver stage (paragraph 5.6).

**5.7.6 OVERLOAD CIRCUIT TRIGGERS WITHOUT OVERLOAD AND CANNOT BE RESET.** The overload circuit is triggered by any instantaneous current or voltage in the output circuit that exceeds the trigger level. Such a current can be caused by a sudden change in any superimposed dc current, by a capacitive discharge when a connection is made, or by other similar transients. This does not necessarily indicate a circuit failure. With some load impedances, the transient caused by resetting the circuit can in turn retrigger the overload circuit if the AMPS switch is on one of its lower ranges. In this case, turn the AMPS switch to a higher range before resetting the OVERLOAD switch.

## 5.8 REAPPLYING POWER AFTER SERVICING.

Because of the high power-handling capacity of this instrument, use caution when again applying power after the instrument is serviced. The following procedure is recommended.

a. With the POWER switch turned OFF, connect the instrument to the power line through a metered Variac<sup>®</sup> adjustable autotransformer. Set the pointer on the transformer at zero and turn on the POWER switch on the panel of the Type 1308-A.

b. Observe the ammeter indication on the metered Variac<sup>®</sup> as the control on the autotransformer is turned slowly clockwise. The current with no load on the instrument, should not exceed 0.80 amperes at 115 volts (65 watts). If this limit is exceeded before rated voltage is reached, turn off the power immediately and correct the trouble before reapplying power. Failure to observe this procedure may result in burned-out wiring, which must be replaced before the instrument can be put in operation again.

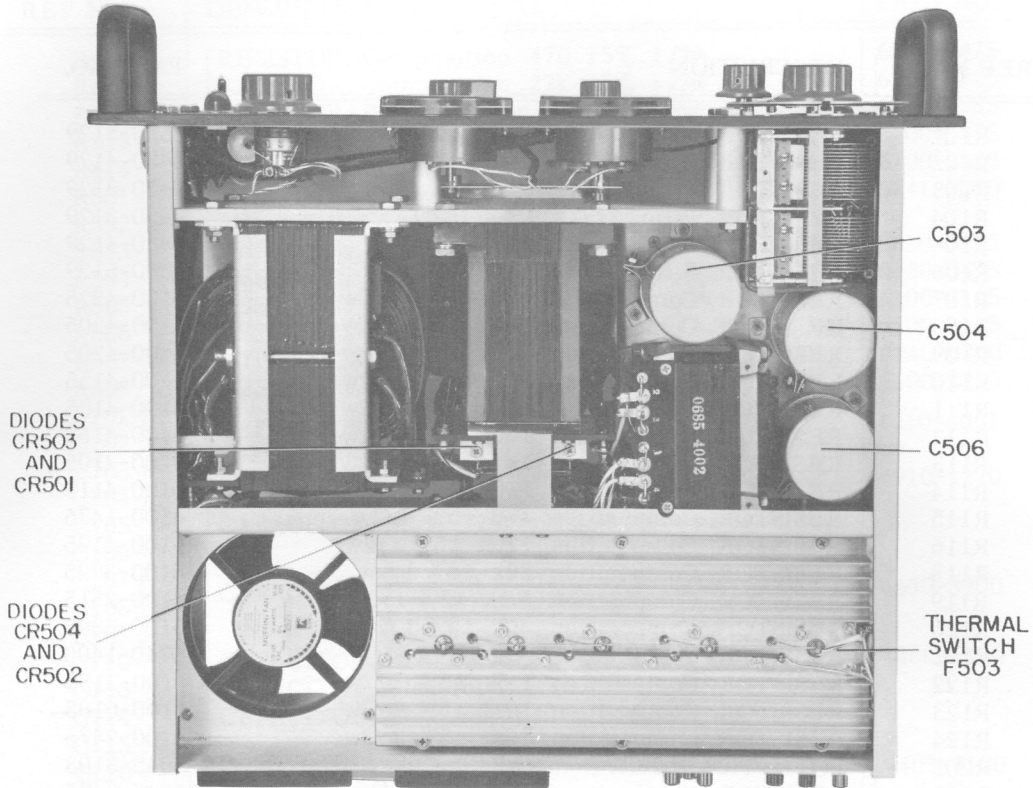

Figure 5-1. Top interior view.

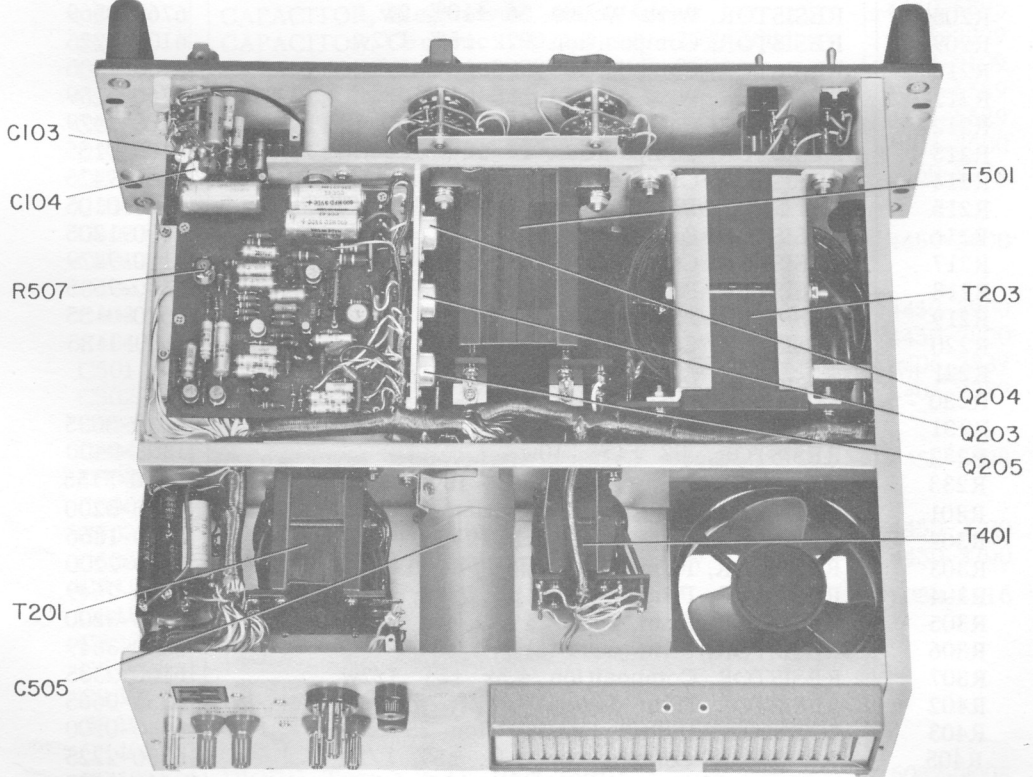

Figure 5-2. Bottom interior view.

## PARTS LIST

REF NO.	DESCRIPTION	PART NO.
R101	RESISTOR, Film 12.9M $\pm 1\%$ 1 w	6550-5129
R102	RESISTOR, Film 1.29M $\pm 1\%$ 1/2w	6450-4129
R103	RESISTOR, Film 129k $\pm 1\%$ 1/2w	6450-3129
R104	RESISTOR, Film 129k $\pm 1\%$ 1/2w	6450-3129
R105	RESISTOR, Film 1.29M $\pm 1\%$ 1/2w	6450-4129
R106	RESISTOR, Film 12.9M $\pm 1\%$ 1w	6550-5129
R107	RESISTOR, Composition 220k $\pm 5\%$ 1/2w	6100-4225
R108	RESISTOR, Composition 200k $\pm 5\%$ 1/2w	6100-4205
R109	RESISTOR, Composition 200k $\pm 5\%$ 1/2w	6100-4205
R110	RESISTOR, Composition 150k $\pm 5\%$ 1/2w	6100-4155
R111	RESISTOR, Composition 180k $\pm 5\%$ 1/2w	6100-4185
R112	RESISTOR, Composition 160k $\pm 5\%$ 1/2w	6100-4165
R113	RESISTOR, Composition 1k $\pm 5\%$ 1/2w	6100-2105
R114	RESISTOR, Composition 110k $\pm 5\%$ 1/2w	6100-4115
R115	RESISTOR, Composition 470 $\pm 5\%$ 1/2w	6100-1475
R116	RESISTOR, Composition 120k $\pm 5\%$ 1/2w	6100-4125
R118	RESISTOR, Composition 22k $\pm 5\%$ 1/2w	6100-3225
R119	RESISTOR, Composition 5.1k $\pm 5\%$ 1/2w	6100-2515
R120	RESISTOR, Composition 30k $\pm 5\%$ 1/2w	6100-3305
R121	RESISTOR, Thermistor	6740-1400
R122	RESISTOR, Composition 1.5k $\pm 5\%$ 1/2w	6100-2155
R123	RESISTOR, Composition 10M $\pm 5\%$ 1/2w	6100-6105
R124	RESISTOR, Composition 3.6k $\pm 5\%$ 1/2w	6100-2475
R201	POTENTIOMETER, Composition 10k $\pm 10\%$	6045-3108
R202	RESISTOR, Composition 47k $\pm 5\%$ 1/2w	6045-3475
R203	RESISTOR, Composition 22k $\pm 5\%$ 1/2w	6045-3225
R204	RESISTOR, Composition 22k $\pm 5\%$ 1/2w	6045-3225
R205	RESISTOR, Composition 10k $\pm 5\%$ 1/2w	6100-3105
R206	RESISTOR, Composition 10k $\pm 5\%$ 1/2w	6100-3105
R207	RESISTOR, Composition 2k $\pm 5\%$ 1/2w	6100-2205
R208	RESISTOR, Wire-Wound 56 $\pm 10\%$ 2w	6760-0569
R209	RESISTOR, Composition 22k $\pm 5\%$ 1/2w	6100-3225
R210	RESISTOR, Composition 100 $\pm 5\%$ 1/2w	6100-1105
R211	RESISTOR, Wire-Wound 180 $\pm 10\%$ 2w	6760-1189
R212	RESISTOR, Composition 4.7k $\pm 10\%$ 1w	6110-2479
R213	RESISTOR, Composition 15 $\pm 5\%$ 1/2w	6100-0155
R214	RESISTOR, Composition 4.7 $\pm 5\%$ 1/2w	6100-9475
R215	POTENTIOMETER, Wire-Wound 10 $\pm 10\%$	6058-0105
R216	RESISTOR, Power 200 $\pm 5\%$ 5w	6600-1205
R217	RESISTOR, Composition 4.7 $\pm 10\%$ 1w	6100-9479
R218	RESISTOR, Power 6.8 $\pm 5\%$ 5w	6660-9685
R219	RESISTOR, Power 15 $\pm 5\%$ 10w	6670-0155
R220	RESISTOR, Composition 180 $\pm 5\%$ 1/2w	6100-1185
R221 to } R230	RESISTOR, ESMW-29-290, 23, Bare, 1 1/4	
R231	RESISTOR, Power 3 $\pm 5\%$ 30w	6630-0035
R232	RESISTOR, .02 $\pm 15\%$ 10w	1308-0400
R233	RESISTOR, Power 15k $\pm 5\%$ 10w	6670-3155
R301	POTENTIOMETER, Composition 300 $\pm 10\%$	6040-0200
R302	RESISTOR, Film 8.66k $\pm 1\%$ 1/4w	6350-1866
R303	RESISTOR, Film 20k $\pm 1\%$ 1/4w	6350-2200
R304	RESISTOR, Film 64.9k $\pm 1\%$ 1/4w	6350-2649
R305	RESISTOR, Film 200k $\pm 1\%$ 1/4w	6350-3200
R306	RESISTOR, Film 649k $\pm 1\%$ 1/4w	6350-3649
R307	RESISTOR, Composition 4.3k $\pm 5\%$ 1/2w	6100-2335
R402	RESISTOR, Film 562 $\pm 1\%$ 1/4w	6350-0665
R403	POTENTIOMETER, Composition 250 $\pm 20\%$	6040-0200
R405	RESISTOR, Composition 2.2k $\pm 5\%$ 1/2w	6350-2225
R406	RESISTOR, Composition 22k $\pm 5\%$ 1/2w	6100-3225
R407	RESISTOR, Composition 1.1k $\pm 5\%$ 1/2w	6100-2115
R408	RESISTOR, Composition 2.2k $\pm 5\%$ 1/2w	6100-2225
R409	RESISTOR, Composition 2.2k $\pm 5\%$ 1/2w	6100-2225



PARTS LIST (continued)

REF NO.	DESCRIPTION	PART NO.
R410	RESISTOR, Composition 470 $\pm 5\%$ 1/2w	6100-1475
R411	RESISTOR, Composition 22k $\pm 5\%$ 1/2w	6100-3225
R412	RESISTOR, Potentiometer 330 $\pm 5\%$ 3w	6680-1335
R413	RESISTOR, Composition 47k $\pm 5\%$ 1/2w	6100-3475
R414	RESISTOR, Composition 6.2k $\pm 5\%$ 1/2w	6100-2625
R501	RESISTOR, Thyrector	6741-1000
R502	RESISTOR, Wire-Wound 6.8 $\pm 10\%$ 2w	
R503	RESISTOR, Potentiometer 47 $\pm 5\%$ 30w	6630-0475
R504	RESISTOR, Potentiometer 47 $\pm 5\%$ 30w	6630-0475
R505	RESISTOR, Composition 2.0k $\pm 5\%$ 1/2w	6100-2165
R506	RESISTOR, Composition 1.1k $\pm 5\%$ 1/2w	6100-2115
R507	POTENTIOMETER, Composition 500 $\pm 20\%$	6040-0300
R508	RESISTOR, Composition 2.2k $\pm 5\%$ 1/2w	6100-2225
C101	CAPACITOR, 603pf	1210-4001
C102		
C103	CAPACITOR, Trimmer 8-50pf	4910-1170
C104		
C105	CAPACITOR, Mica 22pf $\pm 10\%$ 500dcwv	
C106	CAPACITOR, Electrolytic 5 $\mu$ f 50dcwv	4450-3900
C107		
C108		
C109		
C110	CAPACITOR, Electrolytic 100 $\mu$ f 15dcwv	4450-2800
C113	CAPACITOR, Electrolytic 40 $\mu$ f 6dcwv	
C114	CAPACITOR, Electrolytic 10 $\mu$ f 25dcwv	
C115	CAPACITOR, Ceramic 0.1 $\mu$ f +80 -20% 50dcwv	4403-4100
C116		
C117		
C201	CAPACITOR, Plastic 2.2 $\mu$ f $\pm 10\%$ 100v	4860-8300
C202	CAPACITOR, Electrolytic 10 $\mu$ f 25dcwv	4450-3800
C203	CAPACITOR, Electrolytic 10 $\mu$ f 25dcwv	4450-3800
C204	CAPACITOR, Electrolytic 15 $\mu$ f 15dcwv	4450-3700
C205	CAPACITOR, Electrolytic 50 $\mu$ f 3dcwv	4450-5590
C206	CAPACITOR, Electrolytic 400 $\mu$ f 6dcwv	4450-5595
C207	CAPACITOR, Ceramic .0022 $\mu$ f +80 -20% 500dcwv	4405-2229
C208	CAPACITOR, Ceramic .001 $\mu$ f $\pm 20\%$ 500dcwv	4404-2109
C209	CAPACITOR, Electrolytic 600 $\mu$ f 3dcwv	4404-5589
C210	CAPACITOR, Electrolytic 600 $\mu$ f 3dcwv	4404-5589
C211	CAPACITOR, Ceramic .05 $\mu$ f +80 -20% 50dcwv	4403-3500
C212	CAPACITOR, Plastic 1 $\mu$ f $\pm 10\%$ 100v	4860-8274
C301	CAPACITOR, Electrolytic 40 $\mu$ f 6dcwv	4450-3600
C302		
C401		
C402		
C403	CAPACITOR, Electrolytic 5 $\mu$ f 50dcwv	4450-3900
C404	CAPACITOR, Electrolytic 100 $\mu$ f 15dcwv	4450-2800
C501	CAPACITOR, Ceramic .0033 $\mu$ f $\pm 20\%$ 500dcwv	4406-2339
C502	CAPACITOR, Ceramic .0033 $\mu$ f $\pm 20\%$ 500dcwv	4406-2339
C503	CAPACITOR, Electrolytic 12000 $\mu$ f 25dcwv	4450-5598
C504		
C505		
C506		
C507	CAPACITOR, Electrolytic 15 $\mu$ f 15dcwv	4450-3700
C508	CAPACITOR, Electrolytic 15 $\mu$ f 15dcwv	4450-3700
CR101	DIODE, Type 2 RED -1016/1N645	6082-1016
CR102		
CR201	DIODE, Type 2 RED -1008/1N191	
CR202		
CR301	DIODE, Type 2 RED -1008/1N191	
CR302		
CR401	DIODE, Type 2 RED -1008/1N191	6082-1008
CR402		
CR403		
CR404	DIODE, Type 2 REZ -1006/1N753A	6082-1006
CR405	DIODE, Type 2 RED -1016/1N645	6082-1016

## PARTS LIST (continued)

REF NO.	DESCRIPTION	PART NO.
CR501	DIODE, Type 2 RE -1008/1N3493R	6081-1008
CR502	DIODE, Type 2 RE -1007/1N3493	6081-1007
CR503	DIODE, Type 2 RE -1008/1N3493R	6081-1008
CR504	DIODE, Type 2 RE -1007/1N3493	6081-1007
CR505	DIODE, Type 2 REZ -1008/1N957A	6083-1008
F501 } F502 }	FUSE for 115 v FUF-1, 5a	5330-2500
F501 } F502 }	FUSE for 230 v FUF-1, 2.5a	5330-2100
F503	FUSE, Thermal	5320-1402
J201 } J202 }	JACK	4060-0100
J203		4060-0100
J301		4060-1800
J302		4060-0400
J303		4060-1800
L201		INDUCTOR, 56 $\mu$ h
L501	INDUCTOR	0685-4002
M301	METER, 200 $\mu$ a	5730-1361
M401	METER, 200 $\mu$ a	5730-1362
MO501	MOTOR	
P401	PILOT LIGHT, 1.35v .06a	5600-0800
P501	PILOT LIGHT, 6.3v .15a	5600-0900
PL501	PLUG	4240-0600
Q101	TRANSISTOR, Type 2N929	
Q102	TRANSISTOR, Type 2N929	
Q103	TRANSISTOR, Type 2N2188	8210-1045
Q104	TRANSISTOR, Type 2N1304	8210-1304
Q201	TRANSISTOR, Type 2N338	8210-1021
Q202	TRANSISTOR, Type 2N1304	8210-1304
Q203 } Q204 }	TRANSISTOR, Type 2N1905	8210-1016
Q205 }		
Q206 } thru Q215 }	TRANSISTOR, Type 2N1542	8210-1093
Q401	TRANSISTOR, Type 2N520A	8210-5200
Q402	TRANSISTOR, Type 2N910	8210-1037
Q501	TRANSISTOR, Type 2N1131	8210-1374
Q502	TRANSISTOR, Type 2N1304	8210-1304
S101 } S301 }	SWITCH	1308-2020
S302		7890-2970
S401		6045-3108
S402		7890-2980
S501		7910-0400
SO301	SOCKET	7910-1300
T201 } T203 }	TRANSFORMER	4230-0700
T401		0485-4010
T501		0565-4000
		0345-4002
		0565-4010

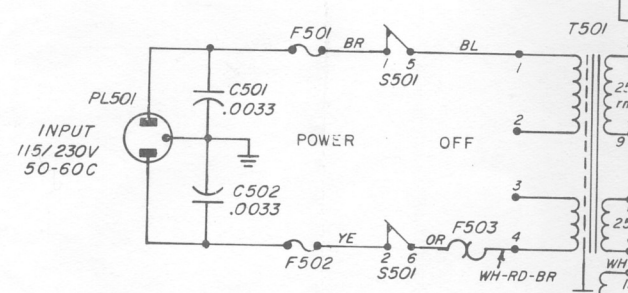
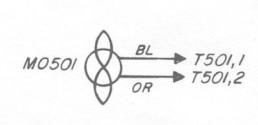
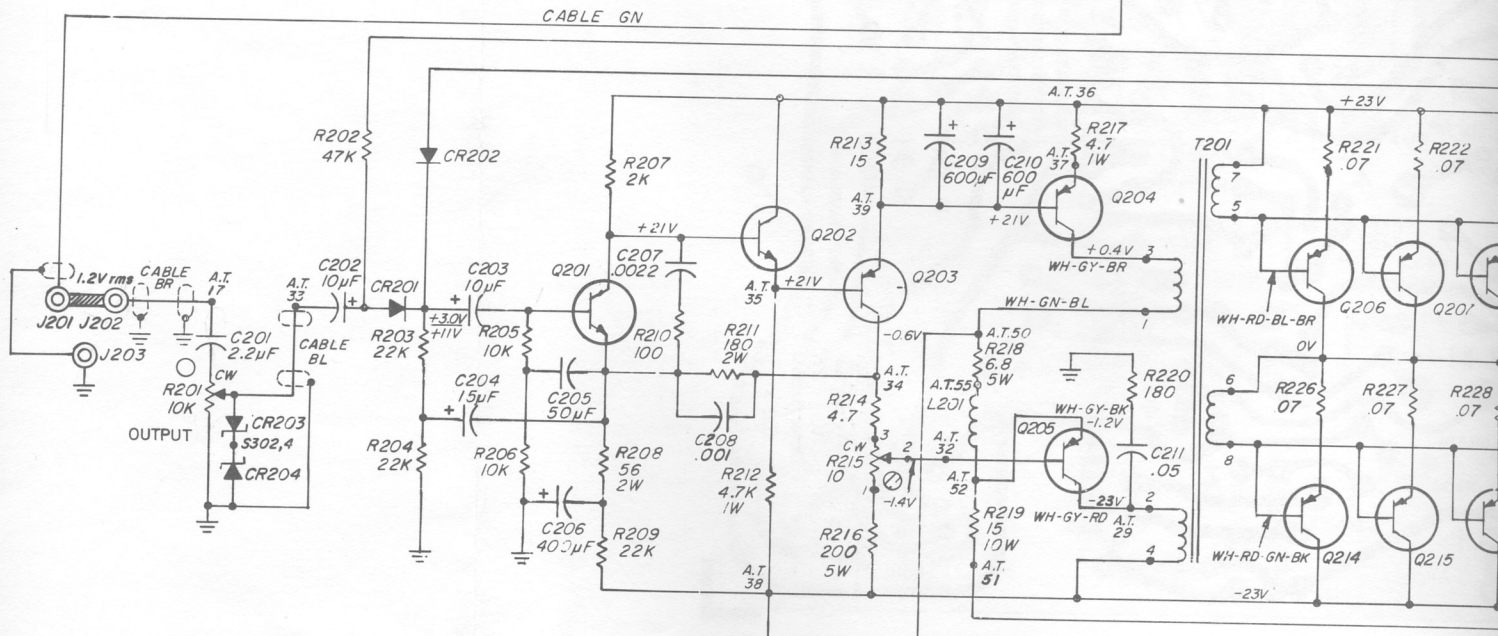
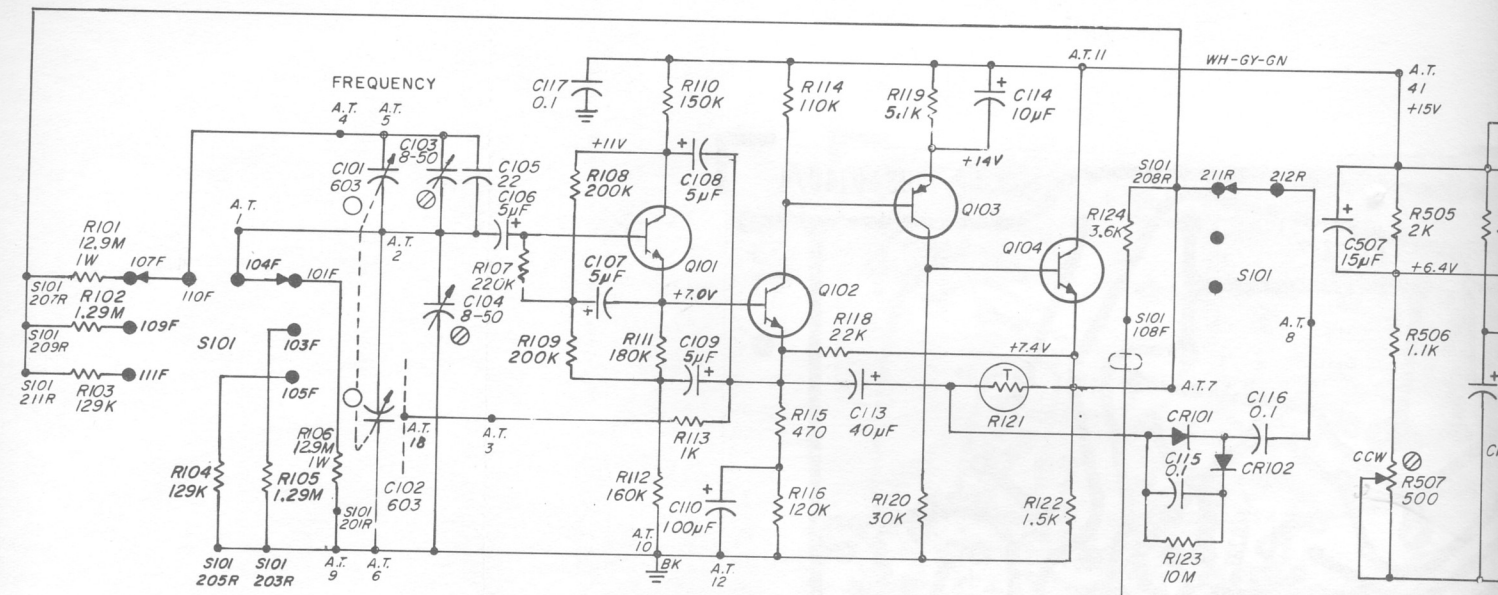

**NOTE FOR T501**  
 FOR 115V OPERATION CONNECT 1 TO 3 & 2 TO 4  
 F501 & F502 = 5 AMP  
 FOR 230V OPERATION CONNECT 2 TO 3  
 F501 & F502 = 2.5 AMP

- FREQUENCY RANGE**
- 20 cps
  - 200 cps
  - 2 kc-2
- S101 LEGEND**

**VOLTAGE MEASUREMENTS**  
 UNLESS NOTED: (NOMINAL VALUES)  
 115V LINE  
 ZERO OUTPUT  
 ALL MEASUREMENTS REFERRED TO  
 GROUND WITH VTVM  
 NOTE: Q401 & Q402 VOLTAGES  
 TOP VALUE: RESET (NORMAL)  
 BOTTOM VALUE: OVERLOAD "ON"



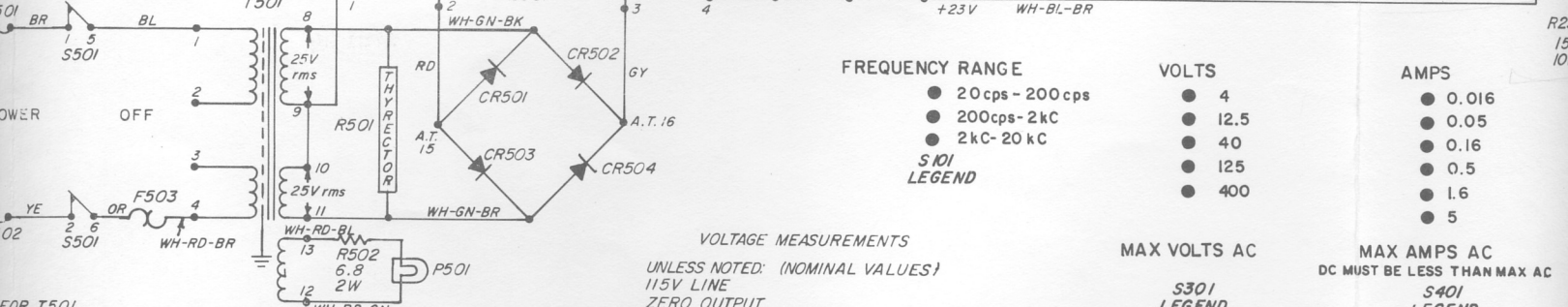
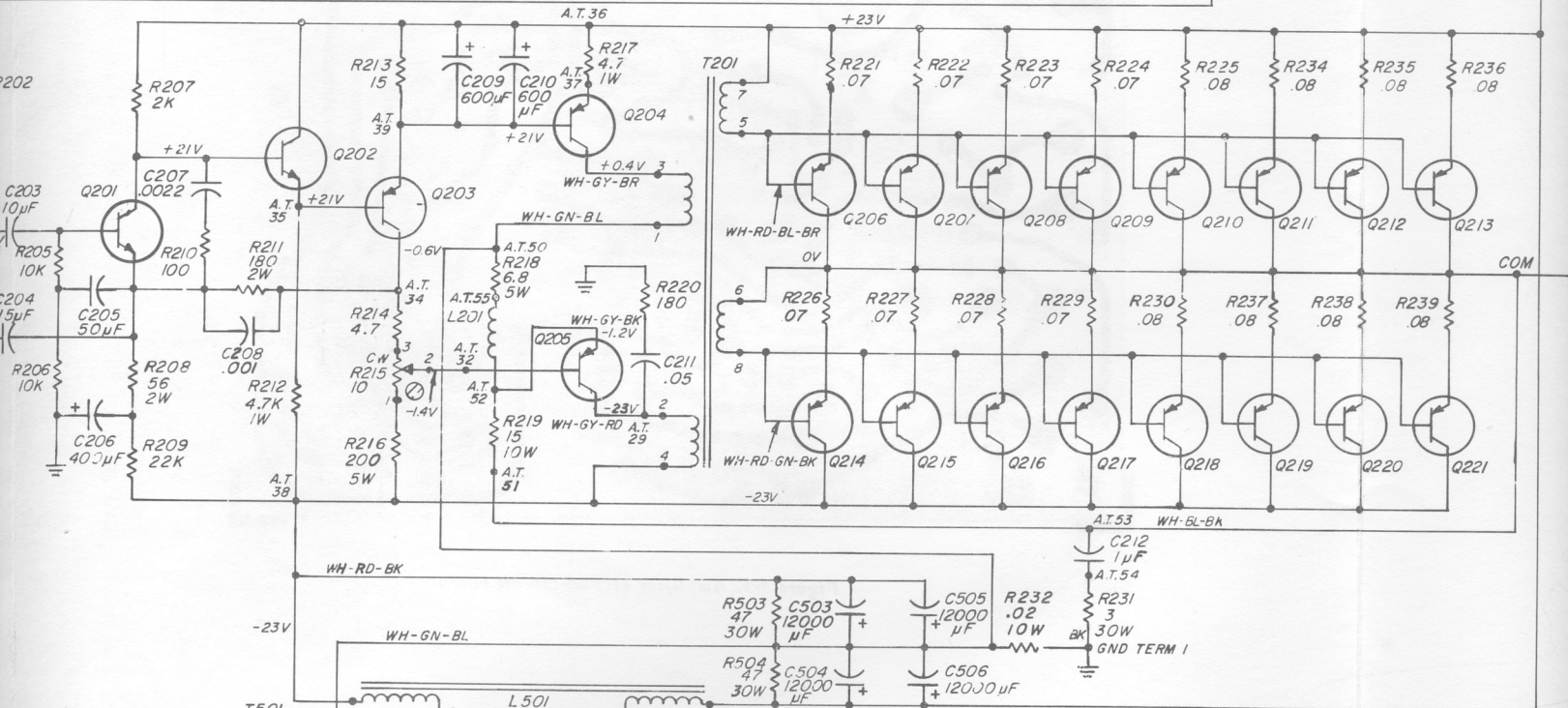
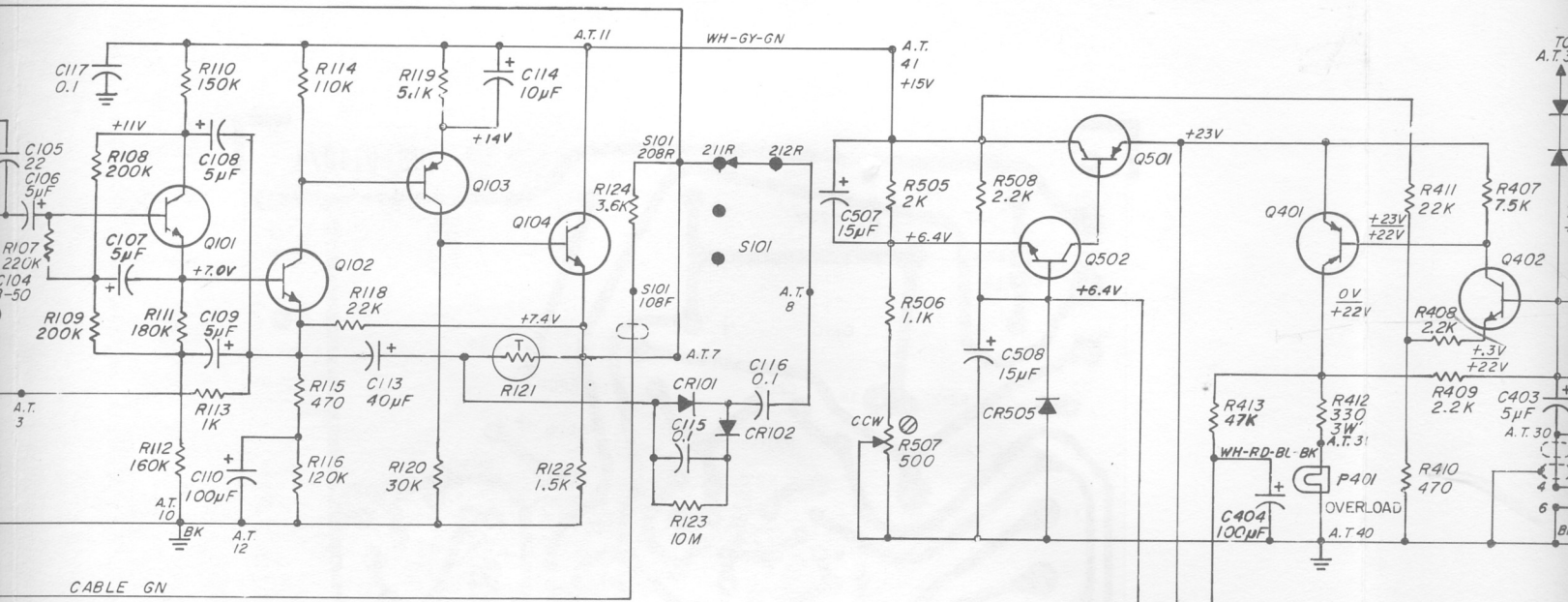

FOR T501  
 FOR 115V OPERATION CONNECT 1 TO 3 & 2 TO 4  
 F501 & F502 = 5 AMP  
 FOR 230V OPERATION CONNECT 2 TO 3  
 F501 & F502 = 2.5 AMP

- FREQUENCY RANGE**
- 20 cps - 200 cps
  - 200 cps - 2 kc
  - 2 kc - 20 kc
- S101 LEGEND**

- VOLTS**
- 4
  - 12.5
  - 40
  - 125
  - 400

- AMPS**
- 0.016
  - 0.05
  - 0.16
  - 0.5
  - 1.6
  - 5

**VOLTAGE MEASUREMENTS**  
 UNLESS NOTED: (NOMINAL VALUES)  
 115V LINE  
 ZERO OUTPUT  
 ALL MEASUREMENTS REFERRED TO GROUND WITH VTVM

**NOTE: Q401 & Q402 VOLTAGES**  
 TOP VALUE: RESET (NORMAL)  
 BOTTOM VALUE: OVERLOAD "ON"

**MAX VOLTS AC**  
**S301 LEGEND**

**MAX AMPS AC**  
 DC MUST BE LESS THAN MAX AC  
**S401 LEGEND**

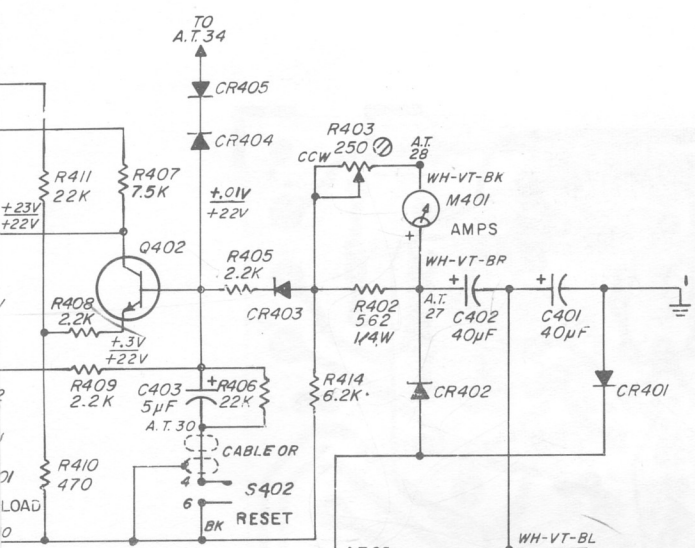

- NOTE UNLESS SPECIFIED**
1. POSITION OF ROTARY SWITCHES SHOWN COUNTERCLOCKWISE.
  2. CONTACT NUMBERING OF SWITCHES EXPLAINED ON SEPARATE SHEET SUPPLIED IN INSTRUCTION BOOK.
  3. REFER TO SERVICE NOTES IN INSTRUCTION BOOK FOR VOLTAGES APPEARING ON DIAGRAM.
  4. RESISTORS 1/2 WATT.
  5. RESISTANCE IN OHMS K 1000 OHMS M 1 MEGOHM
  6. CAPACITANCE VALUES ONE AND OVER IN PICO FARADS. LESS THAN ONE IN MICRO FARADS.
  7. ○ KNOB CONTROL
  8. ⊗ SCREWDRIVER CONTROL
  9. AT ANCHOR TERMINAL
  10. TP TEST POINT

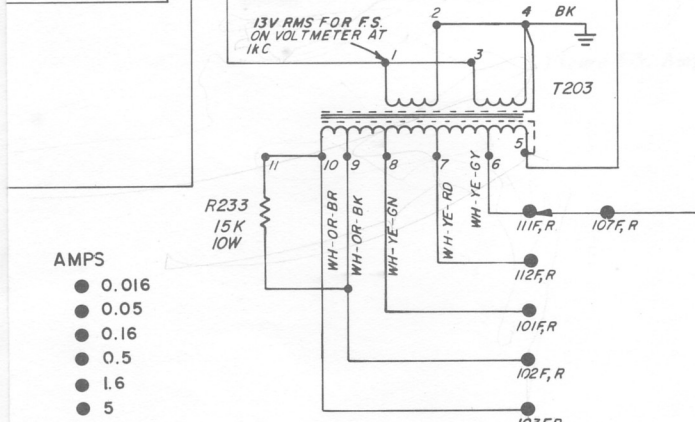
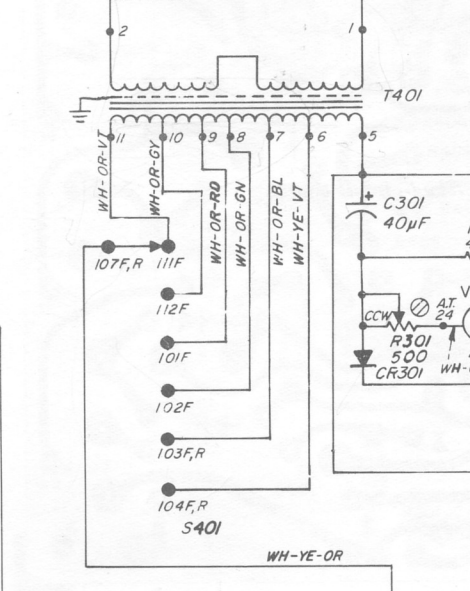
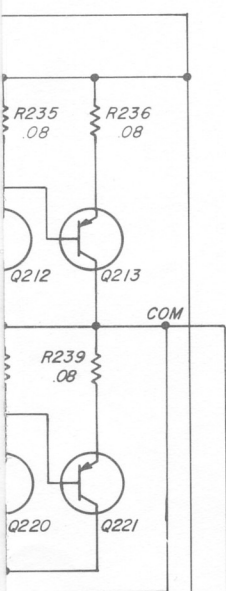

**MAX AMPS AC**  
**JUST BE LESS THAN MAX AC**  
**S401**  
**LEGEND**

- AMPS**
- 0.016
  - 0.05
  - 0.16
  - 0.5
  - 1.6
  - 5

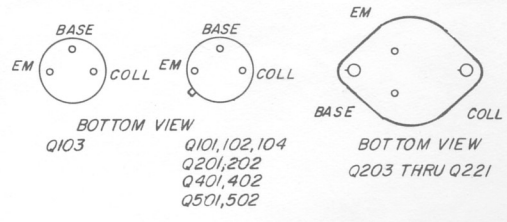
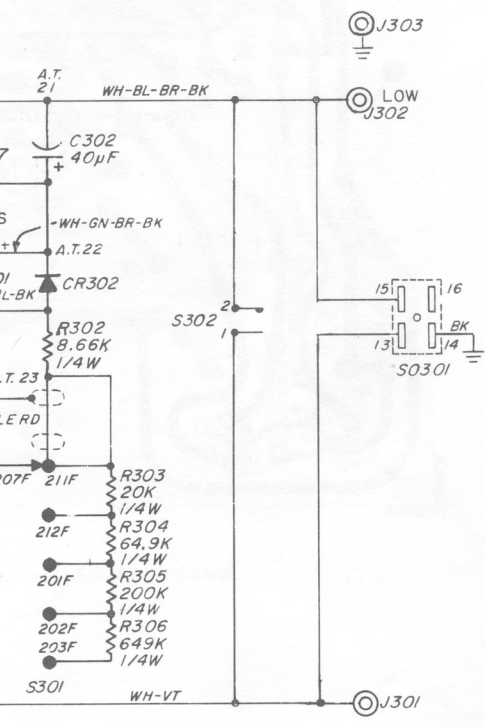

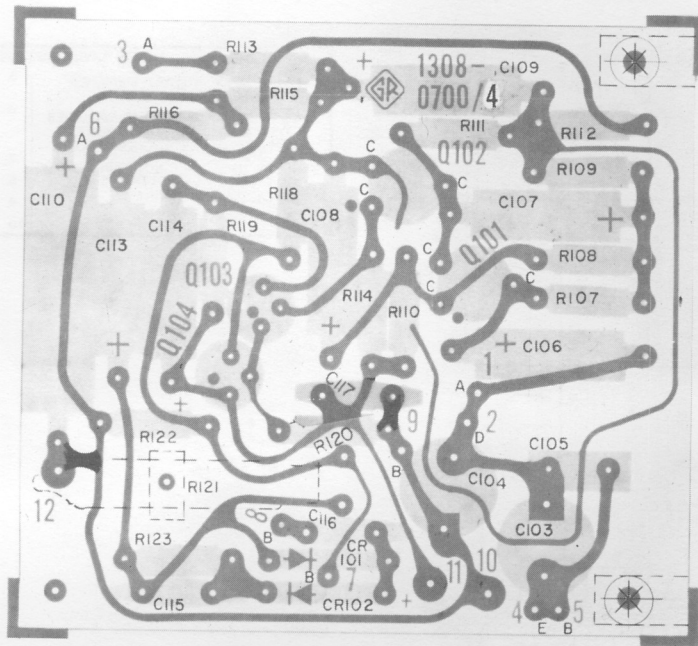

Figure 5-4. Oscillator etched-circuit board.



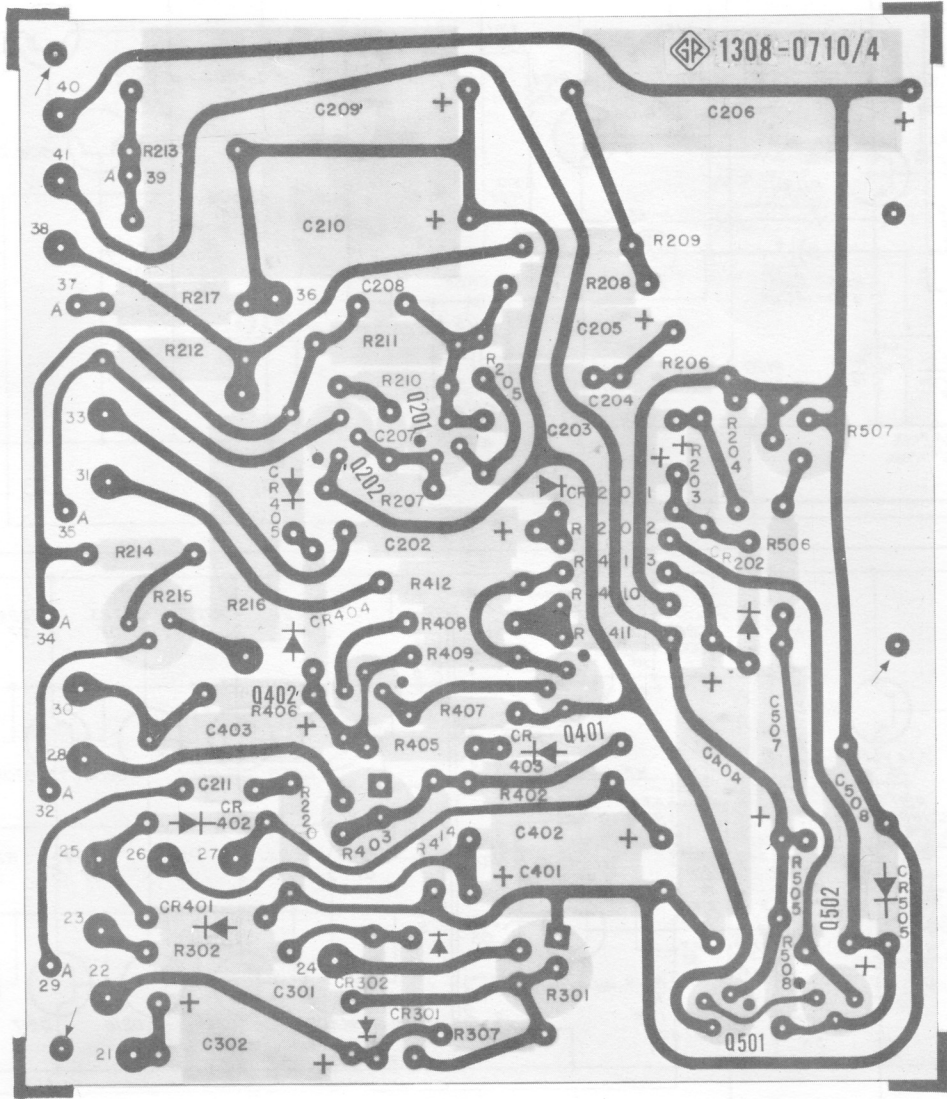

Figure 5-5. Amplifier etched-circuit board.